

CAD Data Folder Name: 47_Casters

CAD Data Folder Name: 47_Casters

Casters used for small / medium-size carriages.

STOCK ITEM
PRINTED IN NAVY



(Rubber Wheel)



(Urethane Wheel)



(Nylon Wheel)

Swivel Type
CNGJ
CNSGJ

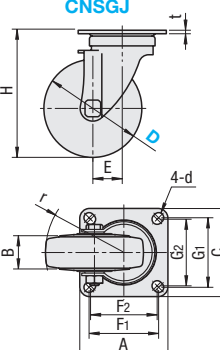

Fixed Type
CNGK
CNSGK

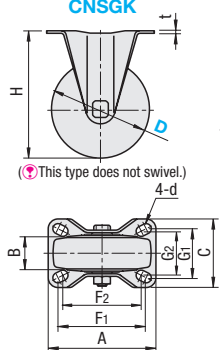

(This type does not swivel.)

Swivel with Stopper Type
CNGS50 / 65 / 75 / 100 / 125 / 150
CNSGS100 / 125 / 150

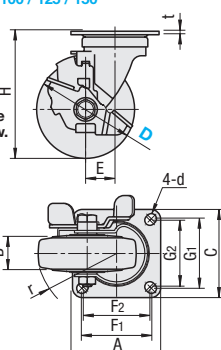

CNSGS65 / 75

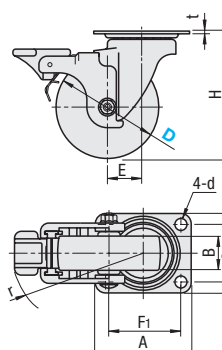

Refer to the figure below.

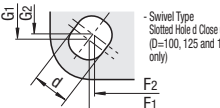

Swivel Type Slotted Hole d Close-up (D=100, 125 and 150 only)

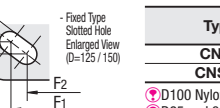

Fixed Type Slotted Hole Enlarged View (D=125 / 150)

Type	Body		Wheel		Bearings	
	M Material	S	M Material (Color)	Swiveling	Wheel	
CNG	SPHC	Trivalent Chromate	Synthetic Rubber (Black) / Urethane (Brown) / Nylon (White)	Incorporated	Provided for D100 / 125 / 150	
CNSG	SUS304	Barrel Grinding (p.158)				

Ⓜ D100 Nylon wheel has no bearing in the wheel.
Ⓜ D25 and 38 rubber wheel color is gray.

Body Type	Part Number Type	Wheel Material	D	Allowable Load (N)										Mass (g)								
				H	A	C	F1	F2	G1	G2	d	E	r	B	Steel	Stainless Steel	Rubber	Urethane	Nylon			
Swivel Type	CNGJ (Steel)	R (Rubber)	25	35	35	30	28	23	4.2	9	24	13	1.5	-	80	-	100	36	37			
	CNSGJ (Stainless Steel)		38	50	46	38	36	28	5.3	13	34	18	-	-	200	-	280	74	75			
			50	65	59	47	46	-	35	-	6.5	16	46	21 (**20)	2	500	-	600	170	140		
			65	85	70	58	55	42	8.8	25	59	25	2.3	2	500	700	700	370	310	300		
			75	93	70	58	55	42	8.8	25	59	25	2.3	2	600	800	800	390	330	320		
Fixed Type	CNGK (Steel)	U (Urethane)	25	130	90	71	68	71	68	10.5	30	84	32 (**29)	2.9	3	1200	1200	1200	1055	930	900	
	CNSGK (Stainless Steel)		38	165	102	102	80	75	80	75	11	35	103	38 (**35)	4	4	1500	1500	1500	1600	1500	1350
			50	190	102	102	80	75	80	75	11	40	120	40 (**35)	4	4	1600	1600	1600	1835	1750	1680
			65	35	37	19	29	-	4.2	-	-	-	13	1.5	-	80	-	100	30	31		
			75	50	46	25	36	-	5.3	-	-	-	18	-	-	200	-	280	51	52		
Swivel with Stopper Type	CNGS (Steel)	N (Nylon)	25	65	58	44	45	-	25	-	6.5	-	21 (**20)	2	500	-	600	130	110			
	CNSGS (Stainless Steel)		38	85	70	52 (**47)	55	28	8.8	-	-	25	2.3	2	500	700	700	260	200	190		
			50	93	70	52 (**47)	55	28	8.8	-	-	25	2.3	2	600	800	800	280	220	190		
			65	130	110	70	90	80	50	45	10.5	-	32 (**29)	2.6	-	1200	1200	1200	770	645	615	
			75	165	140	80	112	100	56	53	11	-	38 (**35)	2.5	-	1500	1500	1500	1100	1000	850	

(**) indicates dimensions for nylon wheels, (*) for urethane wheels and (***) for CNSGK. Ⓜ CNGK25 has 2 mounting holes.

Order Example: Part Number - Wheel Material
CNGJ100 - U

Volume Discount Rate (Round up to the Baht) P87

Qty.	1~19	20~34	35~49	50~99
Rate	Unit Price	5%	10%	18%

Delivery: 1 Day, 5 Days, P87

Unit Price

Part Number Type	D	Steel		Stainless Steel			
		Rubber	Urethane	Rubber	Urethane	Nylon	
CNGJ (Steel)	25	39	-	51	-	-	
	38	56	-	54	-	-	
	50	73	-	73	-	-	
	65	123	237	123	633	738	633
	75	132	269	132	660	815	660
CNSGJ (Stainless Steel)	100	342	551	333	1,543	1,643	1,279
	125	428	792	683	2,262	2,348	2,194
	150	496	956	774	2,489	2,526	2,348
	25	36	-	46	-	-	-
	38	43	-	47	-	-	-
CNGK (Steel)	50	64	-	64	-	-	
	65	96	210	96	278	387	278
	75	114	237	114	301	455	301
	100	264	460	278	942	1,088	815
	125	374	665	592	1,507	1,616	1,470
CNSGK (Stainless Steel)	150	419	824	688	1,789	1,820	1,643
	50	110	-	110	-	-	-
	65	160	305	160	724	829	724
	75	169	333	169	760	915	760
	100	415	610	428	1,752	1,861	1,493
CNGS (Stainless Steel)	125	515	906	765	2,526	2,612	2,476
	150	578	1,042	851	2,744	2,781	2,612

Directions of Stoppers: 7 Days



STOCK ITEM
PRINTED IN NAVY



(Rubber Wheel)



(Urethane Wheel)



(Monomer Casting Nylon Wheel)

Swivel Type
CMGJ

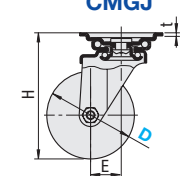

Fixed Type
CMGK

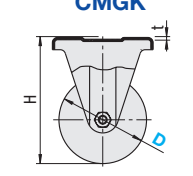

(This type does not swivel.)

Stopper Type
CMGS

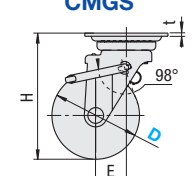

CMGS-L

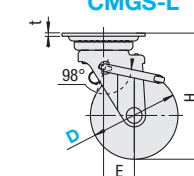

Slotted Hole d Close-up (CMGJ / CMGS)

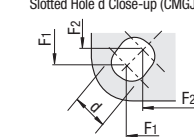

Type	Body		Wheel		Bearings	
	M Material	S	M Material (Color)	Swiveling	Wheel	
CMGJ / CMGK	SPHC	Trivalent Chromate	Synthetic Rubber (Black) / Urethane (Blue) / Antistatic Rubber (Black) / Non-Carbon Antistatic Urethane (Yellow)	Incorporated	Incorporated	
CMGS / CMGS-L	SPHC	Trivalent Chromate	Synthetic Rubber (Black) / Urethane (Blue) / Antistatic Rubber (Black) / Non-Carbon Antistatic Urethane (Yellow)	Incorporated	Incorporated	

Ⓜ indicates the swivel radius of the wheel and turning radius of the pedal.

Body Type	Part Number	Wheel Material	D	H	A	C	F1	F2	G	d	E (r)	B (t)	t	Allowable Load (N)					Mass (g)					Unit Price						
														-R	-U	-N	-T	-K	-R	-U	-N	-T	-K	-R	-U	-N	-T	-K		
Swivel Type	CMGJ	R (Rubber)	75	100	81	63	-	9.5	28	66	32	2.3	2.3	800	1200	1200	800	1200	1700	1060	1240	1130	1060	1010	424	565	815	747	1,534	
			100	144	95	73	70	-	10.5	35	85	32 (34)	3.6	3.6	1200	1700	1800	1200	1700	2600	2000	2210	2040	2000	2310	651	1,070	2,157	1,493	2,963
			130	177	105	-	82	79	-	40	105	38 (42)	4	4	1800	2600	2700	1800	2600	3000	2340	2620	2400	2340	2630	724	1,238	2,407	1,675	2,935
			150	198	120	93	87	-	11	45	120	42 (44)	4	4	2000	3000	3000	2000	3000	3000	2340	2620	2400	2340	2630	724	1,238	2,407	1,675	2,935
			200	250	140	115	105	-	11	58	163	45 (42)	4.5	4.5	2500	3700	4000	-	-	4020	4180	4130	-	-	-	-	-	-	-	-
Fixed Type	CMGK	N (Monomer Casting Nylon)	75	100	95	71	63	-	40	9.5	-	32	2.3	800	1200	1200	800	1200	490	550	490	440	233	478	774	610	1,461			
			100	144	115	80	80	-	45	10.5	-	32 (34)	3.6	3.6	1200	1700	1800	1200	1700	830	1010	920	830	770	314	619	1,052	801	1,643	
			130	177	138	90	100	-	56	11	-	38 (42)	2.9	2.9	1800	2600	2700	1800	2600	1600	1870	1640	1600	1870	519	942	2,053	1,152	2,858	
			150	198	138	90	100	-	56	11	-	42 (44)	4	4	2000	3000	3000	2000	3000	1900	2190	1980	1900	2190	574	1,097	2,289	1,347	3,013	
			200	250	152	100	112	-	63	-	63	45 (42)	4	4	2500	3700	4000	-	-	3350	3540	3460	-	-	-	-	-	-	-	-
Swivel with Stopper Type	CMGS / CMGS-L	T (Antistatic Rubber / Non-Carbon Antistatic Urethane)	75	100	81	63	-	9.5	28	66	32	2.3	2.3	800	1200	1200	800	1200	620	710	620	580	520	528	742	1,015	933	1,984		
			100	144	95	73	70	-	10.5	35	85	32 (34)	3.6	3.6	1200	1700	1800	1200	1700	1170	1350	1240	1170	1080	610	920	1,361	1,384	2,021	
			130	177	105	-	82	79	-	40	105	38 (42)	4	4	1800	2600	2700	1800	2600	2180	2390	2220	2180	2390	860	1,293	2,376	1,989	3,390	
			150	198	120	93	87	-	11	45	130	45 (42)	4	4	2000	3000	3000	2000	3000	2520	2800	2580	2520	2800	920	1,461	2,621	2,171	3,531	
			200	250	140	115	105	-	11	58	-	-	-	-	2500	3700	-	-	-	4250	4410	4360	-	-	-	-	-	-	-	-

No D200 is provided for CMGS-L. (*D100, 130 and 150 are for N wheel dimensions. D200 is for U wheel dimensions.)

Order Example: Part Number - Wheel Material
CMGS130 - U

Volume Discount Rate (Round up to the Baht) P87

Qty.	1~19	20~34	35~49	50~99
Rate	Unit Price	5%	10%	18%

Delivery: 1 Day, 5 Days, P87

- T (Antistatic Rubber) / K (Non-Carbon Antistatic Urethane)
7 Days

