

# COOLING PIPES

— DOWEL PIN TYPE / FLANGE TYPE —



PRINTED IN RED

The quantity discount rate is also applicable to alteration cost.  
All price & lead time are to be quoted.

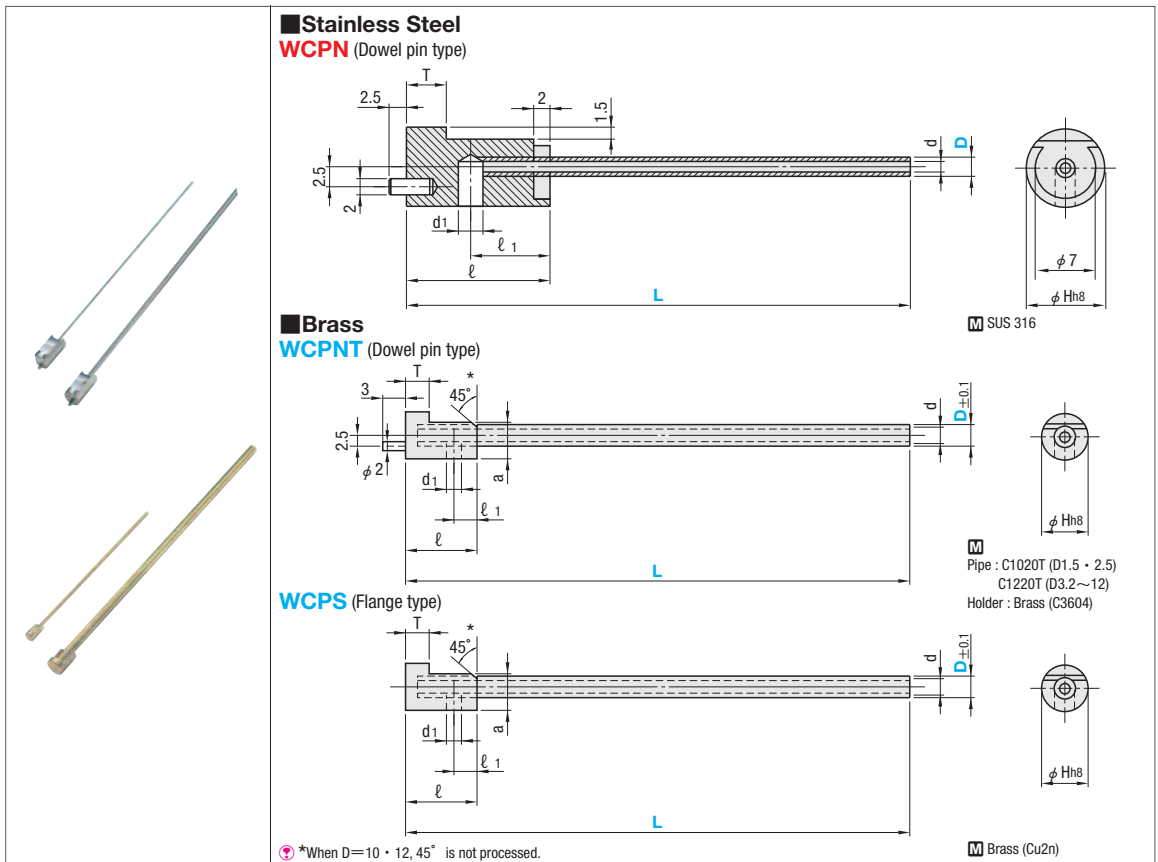

φ Hh8	T	l <sub>1</sub>	l	d <sub>1</sub>	a	d	Part Number		L	U/Price 1~4			
							Type			D	L	WCPN (D≤3.2) WPCS (D≥4)	WCPNT
							Stainless Steel	Brass					
10	0 -0.022	4	10	18	3	8.5	0.9 1.5 2.2(2.0)	WCPN (Dowel pin)	WCPNT (Dowel pin)	1.5	150	Quotation	
										2.5	150		
										3.2	200		
12	0 -0.027	5.1	20	5.4	9.5	5	—	WPCS (D≥4) (Flange)	4	200	Quotation		
6									300				
8									300				
15	0 -0.027	5.6	11	6.5	12	6	—	WPCS (D≥4) (Flange)	10	350	Quotation		
18									350				
22									350				
22	0 -0.033	5.6	11	8.5	11	8	—	WPCS (D≥4) (Flange)	10	350	Quotation		
18	350												
22	350												

WCPNT is dimension in ( ).



Order

Part Number	L
WCPN1.5	150
WCPNT2.5	150
WPCS4	200



Example

D	Recommended φ E
1.5~2	4~5
2.5	5~6
3~3.2	6~7
4~5	8
6	10
8	12
10	16
12	20



Delivery

Printed in Red	Printed in Blue
SGP Stock	3 Days

For area out of Singapore, please refer to Pi.

### Quantity discount rate

Quantity	1~4	5~19	20~49	50~100
Rate	—	5%	10%	15%

To be quoted on price & lead time above Max. Q'ty.

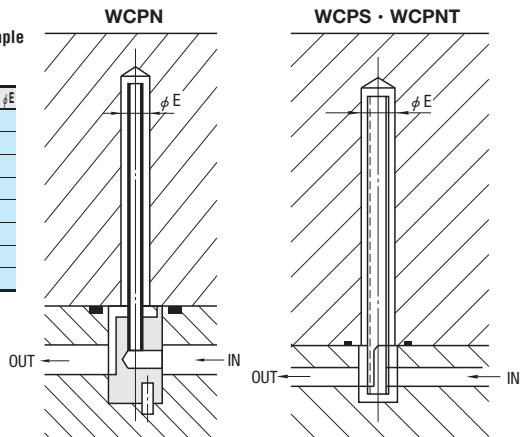

Stocks Availability Subjected to Prior Sales.